

## Operating Instructions

Household Use Multifunctional Hotplate

Model No. NF-X1-N

### Contents page

<b>Safety Precautions</b> .....	2-4
Instructions for Use .....	5
Parts Identification .....	6

Before use

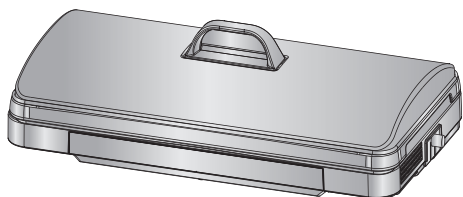

### Preparation

● Recommended pan .....	7
Before cooking & Start cooking .....	8-9
● Timing setting .....	10
Cleaning and Maintenance .....	11
Recipes .....	12-15

Usage

Troubleshooting .....	16
When such a display shows .....	17
Specifications .....	18

In trouble

Chinese please refer to page 19 – back cover.  
( 中文請參考P19 – 尾頁 )

Thank you very much for purchasing the Panasonic product.

- This appliance is intended to be used in household and similar applications.
- Please read this Operating Instructions carefully for safe and proper use of this product. Be sure to read the **"Safety Precautions" (page 2 – 5)** before use.
- Make sure that the information such as date of purchase and dealer's name is stated on the warranty card.
- Keep warranty card together with the Operating Instructions with care.

Reserve it for later use

The Warranty is attached separately





# Safety Precautions

Be sure to observe the following precautions

To prevent personal injury, injury to others and property damage, the following instructions must be followed.

■ The following symbols show the damage or harm level caused by incorrect operation.

 **WARNING:** Indicate a potential hazard which could result in death or serious injury.

 **CAUTION:** Indicate a potential hazard which could result in injury or damage to property.

## WARNING



In order to avoid fire, explosion, scald, injury, electric shock, etc...

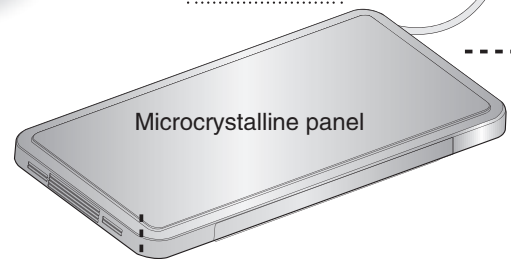
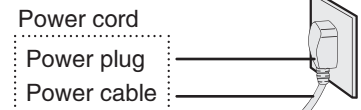

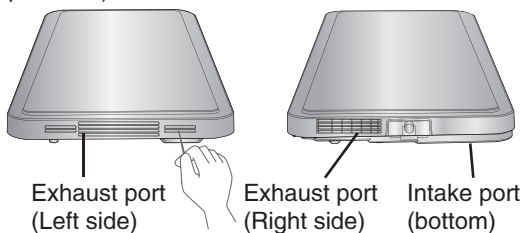

■ Please note to avoid the following operations.

-  ● Do not immerse the appliance in water, shower in water or splash it with water. (So as not to cause an electric shock, or a fire due to a short circuit.)  
→Please make enquiries to the Panasonic authorized service center if water gets inside the appliance.
- Do not use this appliance for any purpose other than those described in the Operating Instructions. (So as not to cause a fire, burn, injury or electric shock.)
  - Panasonic shall not assume any responsibility for improper use or failure to follow the operating instructions.
- Do not modify, disassemble, or repair this appliance. (So as not to cause a fire, electric shock or injury.)  
→For repair, please contact the Panasonic authorized service center.
- Do not insert anything into intake port, exhaust port or gap.
  - Especially pin or other metal objects. (So as not to cause an electric shock or abnormal operation.)



- Keep the appliance out of reach of small children. (So as not to cause a burn, injury or electric shock.)

■ Microcrystalline panel

-  ● Do not impact the microcrystalline panel (such as heavy objects dropping on it, placing heavy objects on it). (So as to avoid electric shock or malfunction.)
- Do not place items other than the special plate/pan on the microcrystalline panel.  
→In particular, pay attention to the following items:
  - Metal items, such as knives, forks, spoons and the cover of the special plate.
  - Sealed items, such as cans, thermos bottles.
  - Low temperature resistant glassware and ceramic ware, such as fruit plates, bowls. (So as to avoid fire, explosion or scald caused by improper heating.)
- Do not put paper, cloth, plastic and other flammable materials on the microcrystalline panel for heating. (So as to avoid fire caused by high temperature.)
-  ● If the surface is cracked, switch off the appliance to avoid potential electric shock. (So as to avoid electric shock.)

■ Classification and description of symbols are as follows.



This symbol indicates an action that is prohibited.



This symbol indicates an action that is must be followed.

## WARNING

### ■ Power supply · Power cord



- Do not use the appliance if the power cord is damaged or the power plug is loosely connected to the power outlet.  
(So as not to cause an electric shock, or a fire due to a short circuit.)  
→If the power cord is damaged, it must be replaced by the manufacturer, its service agent or similarly qualified persons in order to avoid a hazard.

- Do not damage the power cord.
  - Following actions are strictly prohibited.  
Damaging, processing, making it contact with or near high-temperature section, forcibly bending, twisting, pulling, hanging on the corner, placing heavy objects on it, tying into bundles, sandwiching, pulling the power cord to move.  
(So as to avoid electric shock due to damaged power cord or avoid fire due to short circuit.)
- Do not connect or disconnect the power plug with wet hands.
  - Make sure your hands are dry before touching the power plug or the product.  
(So as not to cause an electric shock or injury.)
- Do not spill water or other liquids on the power plug.  
(So as not to cause an electric shock, or a fire due to a short circuit.)



- Make sure that the power plug are fully inserted in place.  
(So as not to cause smoke, fire or electric shock.)

- Please use a alternating current power socket with the voltage of 10 A, 220 V.  
(Using the unit together with other equipment on the same outlet can cause overheating and fire.)
  - Use only a power strip rated at least 10 amperes.
- Single-phase bipolar grounded power outlet should be used for this appliance to ensure reliable grounding. If grounding device is not installed, it may cause electrostatic induction of other metal parts such as housing.  
(So as not to cause the risk of electric shock due to failure or electric leakage.)
- Clean the power plug regularly.  
(So as not to cause a fire due to poor insulation of the power plug arisen from accumulation of moisture and foreign matter.)  
→Disconnect the power plug and wipe it with a dry cloth.

### ■ In use



- Do not leave while frying, stir-frying, barbecuing and making other dishes.  
(So as to avoid fire.)

- Do not move the main body when a pan is placed on it.  
(So as to avoid injuries or damage to the pan.)



- This appliance is not intended for use by persons (including children) with reduced physical, sensory or mental capabilities, or lack of experience and knowledge, unless they have been given supervision or instruction concerning use of the appliance by a person responsible for their safety. Children should be supervised to ensure that they do not play with the appliance.  
(So as not to cause burn, injury or electric shock.)

- When heating liquids, reduce the firepower and stir it from time to time.
  - Please pay special attention when heating soup, curry, etc.  
(So as to avoid burns caused by sudden boiling, liquid splashing.)
- If an exception or malfunction occurs, stop using the appliance immediately and unplug the power plug.  
(So as not to cause smoke, fire or electric shock.)

#### Abnormalities · Malfunction Cases

- The power plug and cord become abnormally hot.
- The power cord is damaged or intermittent power outages when being touched.
- The main body is deformed or abnormally hot.
- The main body emits smoke or burning smell.
- The main body is broken, loose or makes abnormal noise.
- You will feel numb as if being hit by an electric current when touching the main body.  
→Immediately contact the Panasonic authorized service center for inspection or repair.

# Safety Precautions

Be sure to observe the following precautions

## ⚠ CAUTION



In order to avoid fire, explosion, scald, injuries, electric shock, etc....

### ■ In use



● During cooking or at the end of cooking, the temperatures of the following parts are very high, so do not touch.

- Microcrystalline panel, special plate, plate cover, pan, exhaust port, etc.  
(So as to avoid scald.)

● Do not cook with nothing or overheat.  
(So as to avoid scald or damage to the plate coating.)

● Do not connect the appliance with an external timing device or operate the appliance in the mode of a separate remote control system.  
(So as to avoid fire.)

● Do not use this appliance in the following places.  
• Close to heat source or in high humidity environment.  
(So as to avoid electric shock, current leakage or fire.)  
• On uneven table or a mat which is not heat resistant.  
(So as to avoid injury, scald or fire.)

• Close to wall or furniture etc.  
(So as to avoid discoloration, deformation, and breakage of furniture, etc.)  
• On the ground.  
(So as to avoid electric shock.)



● Wait until the main body has cooled down sufficiently before cleaning.  
(So as to avoid scald.)

● This appliance is intended to be used in household and similar applications such as:  
• staff kitchen areas in shops, offices and other working environments;  
• farm houses;  
• by clients in hotels, motels and other residential type environments;  
• bed and breakfast type environments.

### ■ When using the special plate



● Do not expose to steam when opening the plate cover.  
(So as to avoid scald.)



● When the cover handle is loose, re-tighten it before use.  
(So as to avoid scald.)

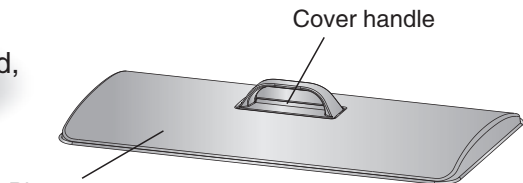
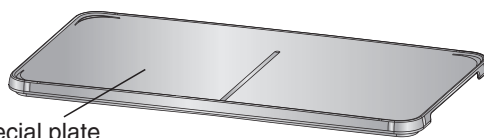
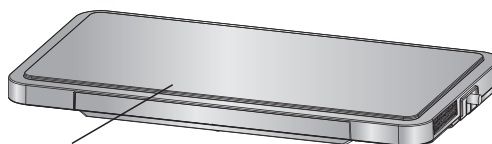

Plate cover



Special plate



Microcrystalline panel

### ■ When frying



● Do not use the oil heated by other equipment.  
• Be sure to use normal temperature (room temperature) oil.  
(So as to avoid fire caused by excessive oil temperature.)

● Please keep your face away.  
(So as to avoid scald.)

● Do not use less than 800 g (0.9 L) of oil when cooking fried dishes.  
(So as to avoid fire caused by excessive oil temperature.)



● If there is a lot of smoke, unplug the power plug immediately.  
(So as to avoid fire.)

● Be careful when the oil is hot and splashes.  
(So as to avoid scalding.)

### ■ Power supply · Power cord



● When you unplug the power plug, be sure to hold the plug itself.  
(So as not to cause an electric shock, or a fire due to a short circuit.)

● When the unit is not in use, remember to turn off the power and unplug the power plug.  
(So as not to cause burns, injury, or an electric shock, leakage, fire due to insulation aging.)

# Instructions for Use

## About the main body

- If the product is on the sliding table, make sure that the load of the table is greater than 12 kg. (So as not to drop the product.)
- Regularly inspect the intake port and exhaust port of the main body, and clean dust. (Refer to "Cleaning and Maintenance" on P11)
- Do not put the ingredients near the exhaust port when in use. (So as not to have the ingredients dried by hot air, which may affect the taste.)
- Do not use the product outdoors. (Unstable power supply may result in a product failure.)
- Avoid using the product under direct sunlight. (So as to avoid color change.)
- Please wait until the main body has cooled down completely before storing it. (So as to avoid scald.)
- Do not use the product where the intake port and the exhaust port of the product may be clogged. For example: on carpet, plastic bag, aluminum foil or fabric, etc. (So as not to increase the internal temperature in the produc.)
- The appliance should be placed horizontally, not against walls or objects, and there should be at least 10 cm space around the appliance, and its exhaust port must be kept clear. (So as to avoid the internal temperature of the appliance to increase.)
- Clean promptly after use to prevent cockroaches and other small insects from entering the appliance. (So as to avoid product failure.)

## About the special plate

- Do not heat seasonings such as sauce for a long time. (So as to avoid stains on the cover of the special plate.)
- Do not use the special plate for products other than this appliance. (So as to avoid deformation of the special plate, and unable to detect the temperature properly.)
- The non-stick coating on the surface of the special plate may be worn out depending on the usage.
  - There may be color specks or the coating may peel off, but product performance or physical health will not be affected.→If necessary, please purchase a new special plate.
- Do not cover the plate to cook with nothing for a long time. (So as to avoid damaging the non-stick coating surface or causing the special plate to deform.)
- Pay attention to the following operations:
  - Do not use sharp objects such as metal spatulas, forks, knives, etc.
  - Handle with care when using, and do not drop or collide with hard objects such as metal.
  - When the plate is still hot, do not place it on mats or plastic products which are not heat resistant, nor use cold water to cool down rapidly.
  - When placing the heat-resistant container, etc., on the plate to keep warm, lay kitchen paper on the surface. (So as to avoid scratches on non-stick coating surface.)
- During use of the special plate, slight deformation may occur due to heating at high temperature, which is normal and should not be worried.

# Part Identification

Please clean the special plate and the plate cover before its first use. (👉 P11)

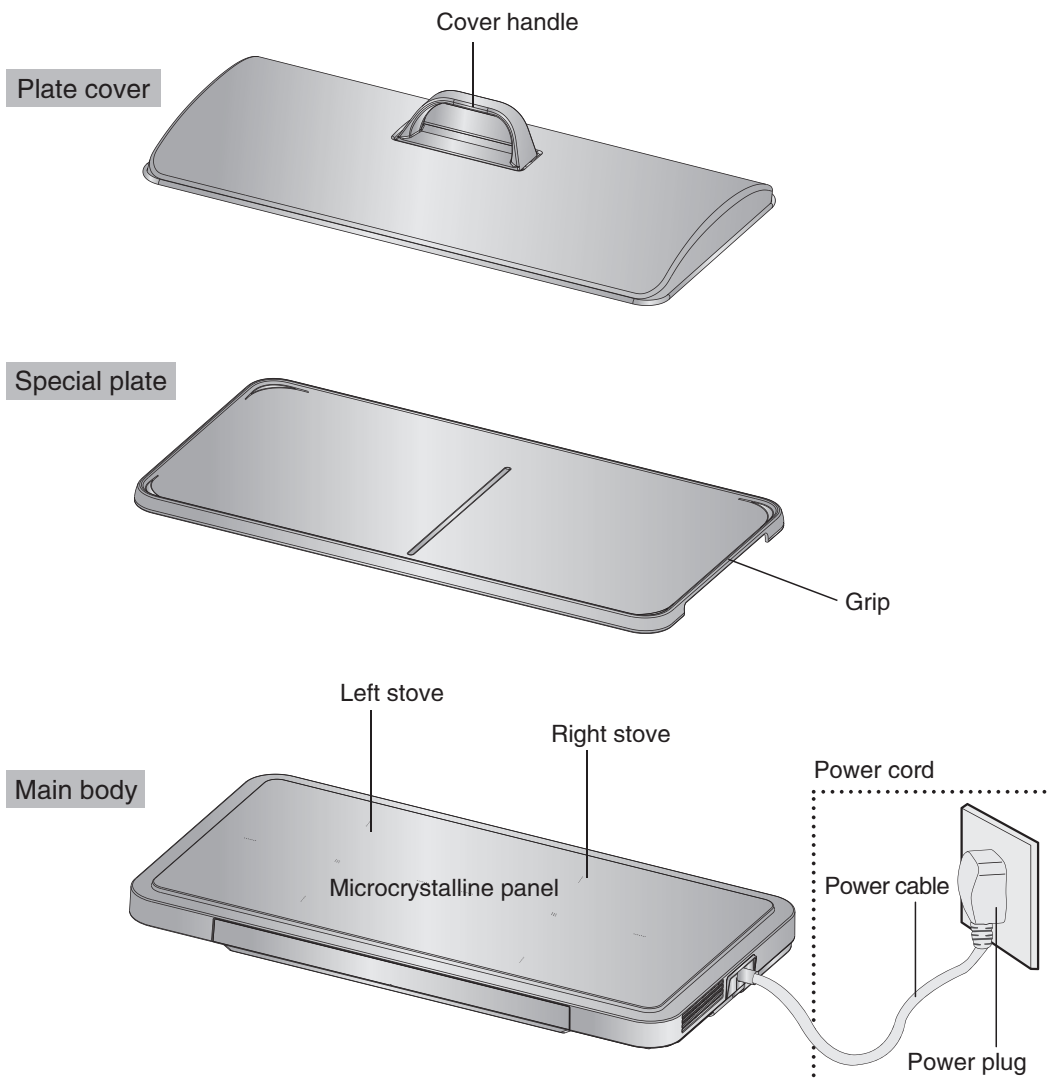

## Control panel



### +/- keys

- To adjust heating temperature or heating level.
- To adjust the time for timing function, and to press and hold the key for fast forward or backward.

### ◀ and ▶ keys

- To select a function.
- To select the stove to be timed when timing the function.

### Off/On key

- To press when cooking starts or ends.

※ If there is residual heat on the surface of the microcrystalline panel after the appliance is switched off, the "Hot" flashes on the control panel, and do not touch, so as to avoid scald.

# Preparation

## Recommended pan



Cooking well

Heating may be affected

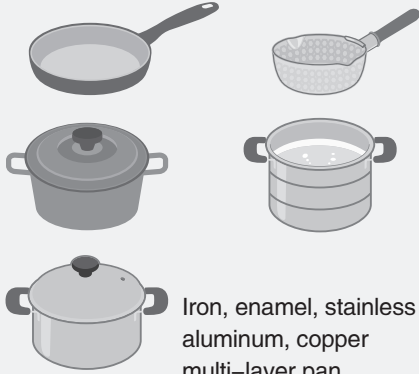

Iron, enamel, stainless steel, aluminum, copper multi-layer pan

- Enameled pans should be avoided from cooking with nothing or burning. (The microcrystalline panel may be damaged as the pans will melt under high temperature.)

Materials



Heat-resistant glass



Casserole

Before use



Flat bottom, fit tightly with the microcrystalline panel

Shape of pan



Round bottom



With support feet



Bent bottom

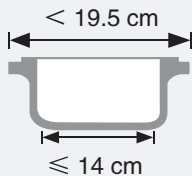

Pan diameter: < 19.5 cm  
(When the left and right stoves are used at the same time)  
Bottom diameter:  $\leq$  14 cm

Size

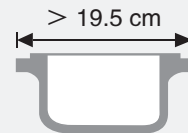

※ Pan with thin bottom may deform after being cooked with nothing or heated by high power. At the same heating level setting, the power consumption of the pan varies depending on its material, shape, size, and so on. The heating performance may also be different.

# Before cooking & Start cooking

## 1 Preparation

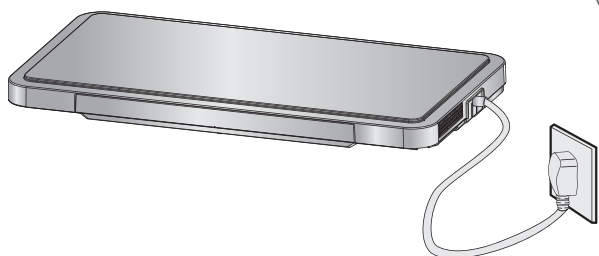
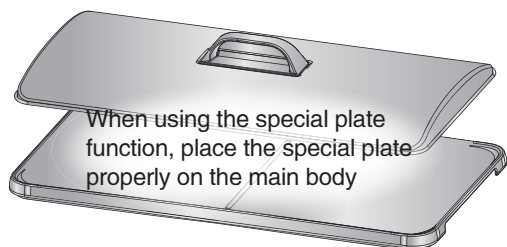

- 1 Please plug in the power plug, and make sure the power plug is fully plugged in.
- 2 Make sure that the power is turned on, and it turns to the standby state.

Standby state



### Tips

It will automatically jump to standby state when not in operation for more than 30 seconds.

When presses [◀] or [▶] and the uncooked state lasts for more than 30 seconds, it automatically jumps to standby state, and does not start heating even if the [Off/On] key is accidentally pressed.

Standby state



Release method:  
Press any key except the [Off/On] key to release.

## 2 Start cooking

### Special plate

Place the special plate properly on the main body

- 1 Press [◀] or [▶] to select the "Special Plate" function.
  - The selected function flashes.

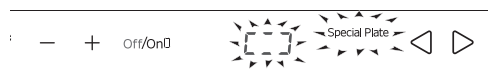

- 2 Select the side of the stove you want to use, and press [Off/On] key to start preheating.
  - During preheating, "Temp." flashes.
  - Default temperature: 220 °C
  - When the left and right stoves are used at the same time, each stove need to be set separately.

Flash during preheating

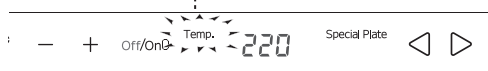

### Others

Place the pan properly on the main body

- 1 Press [◀] or [▶] to select "Others" function.
  - The selected function flashes.

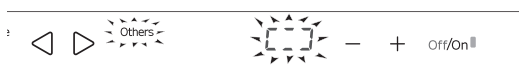

- 2 Select the side of the stove you want to use, and press [Off/On] key.
  - Default heating level: 4 level
  - When the left and right stoves are used at the same time, each stove need to be set separately.

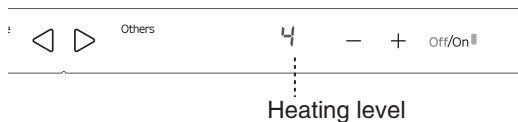



**3** Press the [+] or [-] key to adjust the set temperature.

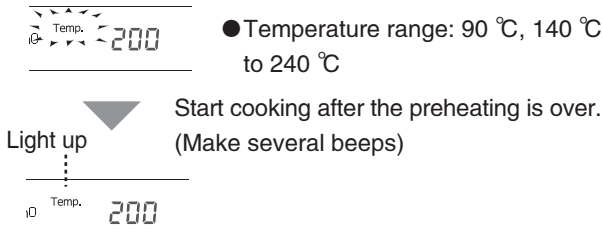

**4** After cooking is complete, press [Off/On] key to turn off.



- When the left and right stoves are used at the same time, the operation is the same and the temperature of each stove needs to be set separately.
- When the left and right stoves are used at the same time, the indication time for beep at the end of preheating will vary depending on room temperature and the usage of the plate.
- In case of uncooled main body, preheating is not required when you reheat the ingredients.

Temperature adjustment recommendations

Temperature appr. (°C)	90	140	160	180	200	220	240
	Warm	Fry eggs		Pancake	Okonomiyaki	Dumplings Steak	Fry noodles BBQ

- Adjust the temperature according to the amount of ingredients, etc.
- It will take longer time when using both the left and right stoves than using a single stove.

**3** Press the [+] or [-] key to adjust the heating level.

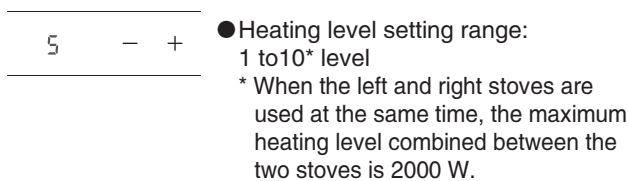

**4** After cooking is complete, press [Off/On] key to turn off.



- When the left and right stoves are used at the same time, the heating level may be limited and become lower than the set heating level.

Power adjustment recommendations

Heating level indication	1	2	3	4	5	6	7	8	9	10
Input power (approx.)	200 W	400 W	600 W	800 W	900 W	1000 W	1100 W	1200 W	1300 W	1400 W
	Gentle heating		Low		Medium			High		
	Simmer slowly				Stew			Quick-fry		
								Fry		

- Adjust the heating level according to the amount of ingredients, etc.

# Start cooking

## Timing setting



If you want to automatically stop cooking after the set time ...

For example: when using the special plate (right side)

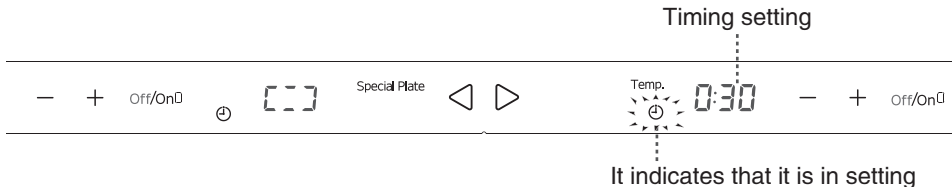

After setting the temperature or heating level in the order of P8 to P9

1



Press [ $\triangleleft$ ] or [ $\triangleright$ ] to select the side of the stove to be timed



●  $\odot$  at the selected side of the stove flashes.

2

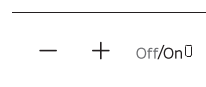

$\odot$  When flashing

Press [+] or [-] to set the timing.

- Press and hold [+] or [-] key for fast forward or backward.
- Setting range: Special Plate mode: 1 minute to 2 hours (1 minute to 9.5 hours can be set for 90 °C)  
Others mode: 1 minute to 3 hours
- The time setting unit is as follows:

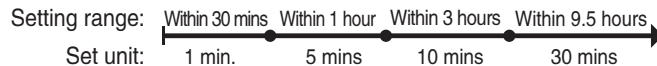

3



$\odot$  It lights up after 3 seconds

The setting is complete.

- When the timing time is displayed, the temperature or heating level is not displayed.
- It stops automatically after cooking.

The left and right stoves can be used at the same time with the same operation.

- The side of the stove available for timing displays the timing setting sign  $\odot$ .

### ■ When canceling the timing setting

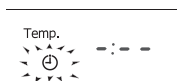

Follow step 1 and 2 to adjust the display time to "--:--" (as shown on the left).

# Cleaning and Maintenance

## Caution

- Make sure to unplug the power plug before cleaning, and wait until the main body has cooled down before washing.
- When cleaning, do not immerse the main body in water, and do not use thinner, gasoline, alcohol, cleaning powder, hard brush, etc.

■ Please wash it promptly when it is dirty.

### Microcrystalline panel

- Wash with diluted dish cleaner, cleaning cloth and water.

- When cleaning up the oil stains  
Wipe with a cleaning cloth moistened with detergent, and then wipe dry with a clean cloth.

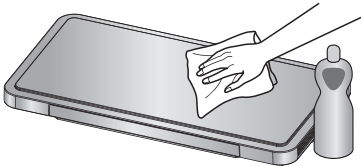

Please use the neutral detergent for kitchen



Do not use the following detergent and tools:

- Acidic or alkaline detergents such as bleach, so as to avoid discoloration.
- Hard brush, cleaning powder, etc. to avoid scratches.



### Special plate and plate cover

- Wash with diluted dish cleaner, soft sponge and water.

Please wipe the water off the plate and its cover promptly.

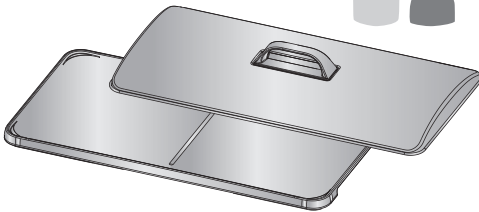
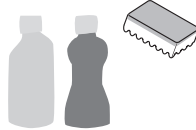

- Do not use a nylon brush or the nylon finish of a scouring pad.
- Do not use the dish washer or dish dryer.
- Do not place cooked meals in the plate for a long time, or do not leave the plate with water and detergent for a long time.  
(So as to avoid any impact on the fluoride coating.)

### Main body (intake/exhaust ports)

- Inspect about once a month, and wash immediately if there is dirt.

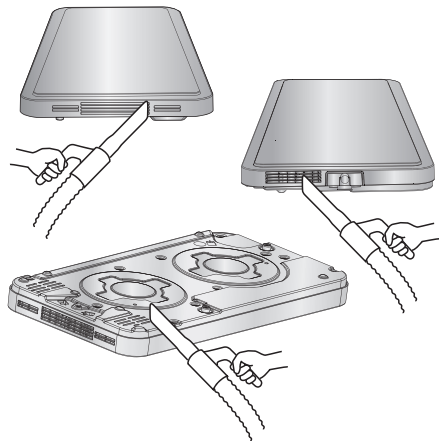

Suck garbage and other foreign objects with a vacuum cleaner.

# Recipes

Tips: The recommended temperature, heating level, amount of ingredients, and time in the recipe can be adjusted according to your preference, size of ingredients, and usage of the appliance.

## Dumplings



Both sides of the plate

### Ingredients:

Quick-frozen dumplings 15 pieces

### Seasonings:

Oil 20 mL  
Water To taste

### Steps:

- 1) Pour oil into the special plate, brush it evenly all around, and press [ $\triangleleft$ ] or [ $\triangleright$ ] to select the "Special Plate" function, press the [Off/On] keys for the left and right stoves, and then set the temperature to 220 °C by pressing the [+] or [-] key.
- 2) After preheating, arrange the dumplings in order in the special plate, sprinkle some clean water, and then cover with the outer lid.
- 3) After 8 to 10 minutes, open the outer lid, and if the dumplings are brown on the bottom, turn it over one by one and pan-fry for about 5 minutes, or if they have not yet been brown, wait some time and then turn over to pan-fry.

## Mixed fried noodles



Both sides of the plate

### Ingredients:

Noodles 50 g  
Sausages 30 g, dice  
Shiitake mushrooms 30 g, dice  
Onions 20 g, dice

### Seasonings:

Oil To taste  
Soy sauce 20 mL

### Steps:

- 1) After blanching the noodles, take them out and drain out of water, then add 10 mL of oil into the noodles and mix well for the next step.
- 2) Pour the oil into the special plate, brush it evenly all around, and press [ $\triangleleft$ ] or [ $\triangleright$ ] to select the "Special Plate" function, press the [Off/On] keys for the left and right stoves, and then set the temperature to 240 °C by pressing the [+] or [-] key.
- 3) After preheating, put sausages, shiitake mushrooms and onions into the special plate to stir-fry for about 1 minute, and add noodles and soy sauce to stir-fry evenly for 5 minutes.

## Pan-fried basa fish



Both sides of the plate

### Ingredients:

Basa fish 200 g

### Seasonings:

Salt A little  
Black pepper A little  
Oil To taste

### Steps:

- 1) Pickle the basa fish with salt and black pepper for 5 to 10 minutes.
- 2) Pour the proper amount of oil into the plate, brush it evenly all around, and press [ $\triangleleft$ ] or [ $\triangleright$ ] to select the "Special Plate" function, press the [Off/On] keys for the left and right stoves, and then set the temperature to 220 °C by pressing the [+] or [-] key.
- 3) After preheating, put the basa fish in the plate, fry until the bottom of the fish is slightly brown, turn it over to fry until the other side is slightly brown.

# Recipes

## Casual BBQ



Both sides of the plate

### Ingredients:

Meat for BBQ                      Appropriate amount  
(thinly sliced beef, lamb, streaky pork, etc.)  
Favorite vegetables and mushrooms  
   Appropriate amount  
(Enoki mushrooms, potato chips, etc.)

### Seasonings:

Oil                                      To taste  
BBQ sauce                          To taste  
Salt                                     A little  
Pepper                                A little

### Steps:

- 1) Pour oil into the special plate, brush it evenly all around, and press [ $\triangleleft$ ] or [ $\triangleright$ ] to select the "Special Plate" function, press the [Off/On] keys for the left and right stoves, and then set the temperature of the left and right stoves to 240 °C and 180 °C respectively by pressing the [+] or [-] key.
- 2) After preheating, put meat ingredients in the plate at 240 °C and vegetables and mushrooms in the plate at 180 °C, and sprinkle some salt and pepper over it. After toasting one side, turn it over to toast until done.

## Steak



Both sides of the plate

### Ingredients:

Steak                                  Several slices, about 100 g/slice  
(About 1.0 cm thick, marinated)

### Seasonings:

Oil                                      A little

### Steps:

- 1) Press [ $\triangleleft$ ] or [ $\triangleright$ ] to select the "Special Plate" function, press the [Off/On] keys for the left and right stoves, and then set the temperature of the left and right stoves to 220 °C and 140 °C respectively by pressing the [+] or [-] key.
- 2) After preheating is complete, brush the plate at 220 °C with oil and put the steak in, fry it for 2 minutes, and then turn it over to fry for another 1 minute and 30 seconds. Place the fried steak to the plate at 140 °C to fry for 1 minute, then turn it over to fry for another 1 minute (the frying time is based on your preference).

## Golden fried rice



Both sides of the plate

### Ingredients:

Cold rice                              200 g  
Egg                                        1  
Shelled shrimps                    30 g  
Onions                                  20 g, dice  
Sausages                                30 g, dice

### Seasonings:

Oil                                      To taste  
Soy sauce                            15 mL  
Salt                                     A little

### Steps:

- 1) Pour oil into the special plate, brush it evenly all around, and press [ $\triangleleft$ ] or [ $\triangleright$ ] to select the "Special Plate" function, press the [Off/On] keys for the left and right stoves, and then set the temperature to 220 °C by pressing the [+] or [-] key.
- 2) Beat the eggs, and pour in the egg paste after preheating. After stir-frying and chopping the eggs, put sausages, onions and shelled shrimps into the special plate to stir-fry with the eggs for about 1 minute, and then add cold rice, salt and soy sauce to stir-fry all together for 6 to 7 minutes.

# Recipes

## Bacon and enoki mushrooms



### Ingredients:

Bacon                      Several slices  
enoki mushrooms        30 g

### Seasonings:

Black pepper            To taste  
Oil                         To taste

Both sides of the plate

### Steps:

- 1) Wash the enoki mushrooms and cut into segments about 5 cm long. Take about 6 or 7 enoki mushrooms to roll in with a piece of bacon and fix them with toothpicks. Make all the rolls in order.
- 2) Pour the proper amount of oil into the plate, brush it evenly all around, and press [ < ] or [ > ] to select the "Special Plate" function, press the [Off/On] keys for the left and right stoves, and then set the temperature to 180 °C by pressing the [+] or [-] key.
- 3) After preheating, put the bacon rolls in the plate, fry until the bottom of the roll is slightly brown, turn it over to fry until the other side is slightly brown, and finally sprinkle black pepper over it.

## Hong Kong Toast



### Ingredients:

Toast                      several pieces  
Eggs                        2

### Seasonings:

Oil                         To taste  
Peanut butter            To taste  
Condensed milk         To taste

Both sides of the plate

### Steps:

- 1) Cut off the edges of the toast slice and divide it into four equal parts. Take a piece of toast spread with peanut butter, cover it with a layer of toast, then spread condensed milk on it, and cover it with a slice of toast.
- 2) Beat the eggs, and coat the folded toast with egg mixture.
- 3) Press [ < ] or [ > ] to select the "Special Plate" function, press the [Off/On] keys for the left and right stoves, and then set the temperature to 160 °C by pressing the [+] or [-] key.
- 4) After preheating, brush a layer of oil on the plate, put in the toast and fry it until both sides are golden brown.

## Pancake



### Ingredients:

Eggs                        2  
Milk                        100 mL  
Cake powder            100 g  
                                  (need to beat to foaming)  
Baking powder         3 g

### Seasonings:

Butter                     20 g  
Sugar                      40 g

Both sides of the plate

### Steps:

- 1) Beat the eggs, add sugar and milk in it, stir evenly, and add cake powder and baking powder in several times to stir evenly, and then add butter. The cake batter is complete.
- 2) Press [ < ] or [ > ] to select the "Special Plate" function, press the [Off/On] keys for the left and right stoves, and then set the temperature to 180 °C by pressing the [+] or [-] key.
- 3) After preheating, lay the cake batter made in step 1) onto the special plate (one rice spoon for each).
- 4) When bubbles appear on the surface and solidify, turn it over to pan-fry the other side until slightly brown.

# Recipes

## Egg and potato cakes

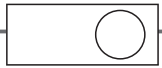

One stove

### Ingredients:

Potatoes	150 g
Eggs	2
Chopped spring onion	To taste

### Seasonings:

Salt	1 g
Starch	20 g
Oil	15 mL

### Steps:

- 1) Cut the potatoes into shreds, do not wash them with water, put in starch and eggs, and stir evenly until there is no dry starch.
- 2) Put the chopped spring onions in, stir it evenly, and add salt and pepper.
- 3) Pour oil in the pan and pour in the freshly mixed potato shreds and spread them evenly.
- 4) Press [ < ] or [ > ] to select the "Others" function, press the [Off/On] keys for the left and right stoves, and then set the heating level to "6" by pressing the [+] or [-] key. Fry until the bottom of the cake is brown, and turn it over to fry until the other side is brown.

## Dishes steamed in tea bowls

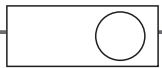

One stove

### Ingredients:

Eggs	1
Shelled shrimps	2 pieces
Shiitake mushrooms	2 pieces
Water	To taste

### Seasonings:

Salt	A little
Cooking wine	10 mL

### Steps:

- 1) Beat the eggs with water by 1:3, and put a small amount of salt, and cooking wine, mix them evenly and remove the foam, pickle the shelled shrimps with salt and cooking wine for 5 minutes, and soak the shiitake mushrooms in the water, and then wash and slice the shiitake mushrooms.
- 2) Put 1 shelled shrimp on the bottom of the tea bowl, pour the beaten eggs into 80% of the bowl, cover with the cup lid (or with plastic wrap if no lid), and put it in the water-filled pan.
- 3) Press [ < ] or [ > ] to select "Others" function, press the [Off/On] key and then set the heating level to "8" by pressing the [+] or [-] key. After the water boils, steam for about 8 minutes, then open the lid, put 1 shelled shrimp and 2 pieces shiitake mushrooms in each bowl, and close the lid and steam for another 8-10 minutes.

## Oden

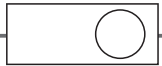

One stove

### Ingredients:

White radish	100 g
Kelp knots	Appropriate amount
Favorite ingredients (meatballs, potatoes, etc.)	Appropriate amount
Water	1000 mL

### Seasonings:

Oden soup	1 pack
-----------	--------

### Steps:

- 1) Pour the oden soup (prepared with water) into the pan, peel the white radish and cut into 2 cm or so thick pieces, and put radish pieces in the pan with kelp knots.
- 2) Press [ < ] or [ > ] to select the "Others" function, press the [Off/On] key, and then set the heating level to "8" by pressing the [+] or [-] key.
- 3) After 10 minutes of stewing, add your favorite ingredients, adjust the heating level to the "4" by pressing the [+] or [-] key, and continue to boil for about 45 minutes to make it tasty.

# Troubleshooting

It is not a fault, and please check before requesting a repair.

Phenomenon	Please check
There is no reaction after pressing each key	<ul style="list-style-type: none"><li>● Is the power plug plugged?</li></ul>
When in use return to standby	<ul style="list-style-type: none"><li>● If there is no operation for a certain period of time (approximately two hours), it will automatically stop heating (protection function is activated) and return to standby.</li><li>● Have you set the timing function?</li></ul>
When in use the heating power is weaker	<ul style="list-style-type: none"><li>● "Excessive temperature rise prevention" function is activated.<ul style="list-style-type: none"><li>· If the temperature of the pan is dramatically increased over the long heating time, the power will be automatically controlled. (When the temperature drops, the heating level automatically gets high.)</li><li>· When cooking with nothing. (Please check the situation in the pan.)</li></ul></li></ul>
When the left and right stoves are used at the same time <ul style="list-style-type: none"><li>● The heating level becomes low</li><li>● The heating level display automatically becomes low</li><li>● The heating level cannot become high</li></ul>	<ul style="list-style-type: none"><li>● To keep within the total input power, it will be automatically adjusted to limit the heating level.</li></ul>
When frying, the preheating time is too long or the oil temperature is too low	<ul style="list-style-type: none"><li>● Is hot oil used for preheating?</li><li>● Is it used for cooking when the microcrystalline panel has not cooled down?</li><li>● Is the bottom of the pan or microcrystalline panel dirty?</li><li>● Is hot oil, dark brown oil or muddy oil used?</li><li>● Is there any fried residue?</li></ul>
When the "Special Plate" function is used on both right and left stoves, the time for beep is different when preheating is complete	<ul style="list-style-type: none"><li>● Even if the set time is the same, the time for beep on the left and right stoves may vary due to the room temperature, the usage and temperature of the special plate.</li></ul>
The fan makes a noise when not in use	<ul style="list-style-type: none"><li>● The cooling fan starts when the internal temperature of the main body is too high. (When the temperature drops, it will automatically stop.)</li></ul>

## Caution

When the product cannot heat up or the heating level weaken continuously, please remove the plug and re-insert it, select the function, and press the [Off/On] key.





# Specifications

Model No.		NF-X1-N
Rated voltage		220 V~
Rated frequency		50 Hz
Rated power input		2000 W for two stoves, 1400 W for one stove
Temperature adjustment	Warm	90 °C
	Heating	140 °C – 240 °C
Heating level adjustment	Others functions	1 – 10 level
Power cord length (approx.)		1.8 m
Main body	Size (approx.) (W × D × H)	472 mm × 260 mm × 48 mm
	Weight (approx.)	3.4 kg
Special plate	Size (approx.) (W × D × H)	459 mm × 249 mm × 86.6 mm (including plate cover)
	Weight (approx.)	2.0 kg (including plate cover)

## 使用說明書

家庭用 多功能電熱盤

型號: NF-X1-N

### 目錄 頁碼

安全注意事項 .....	20-22
使用注意事項 .....	23
零件名稱 .....	24

使用前

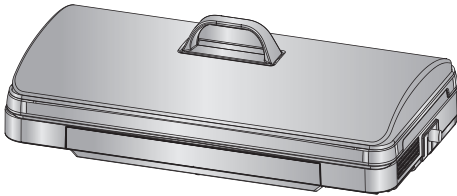

### 準備

● 推薦用鍋 .....	25
烹調前&開始烹調 .....	26-27
● 定時設定 .....	28
清潔保養 .....	29
食譜 .....	30-33

使用方法

非常感謝您購買Panasonic產品。

- 本產品用於家庭和類似用途。
- 請仔細閱讀本使用說明書，以確保正確安全使用本產品。使用前請務必閱讀【安全注意事項】(第22 - 24頁)。
- 請確保保修卡上註明有購買日期和經銷商號等信息。
- 將保修卡和使用說明書一同小心收妥。

疑難排解 .....	34
當出現這樣的顯示時 .....	35
規格 .....	封底

困惑時

保留備用

保修卡另附

# 安全注意事項

請務必遵守!

為防止造成人身傷害、財產損失，請務必遵守以下安全注意事項。

■ 以下圖表顯示錯誤操作可導致的損壞程度。



## 警告

表示如不避免，則可能導致死亡或嚴重傷害的某種潛在危害情況。



## 注意

表示如不避免，則可能導致輕微或中度傷害的某種潛在危害情況。



## 警告



為避免火災、爆炸、燙傷、受傷、觸電等……

### ■ 請注意避免以下操作。



- 請勿淋水、直接用水清洗或把產品浸在水中。

(以免導致觸電或因短路導致火災。)

→如果本產品進水，請諮詢Panasonic授權的服務中心。

- 請勿將產品用於使用說明書記載以外的任何用途。

(否則可能會導致火災、燒傷、受傷或觸電。)

· 對於使用不當或未能遵守使用說明書而導致的情况，Panasonic將不承擔任何責任。

- 請勿自行改裝、拆解或修理產品。

(以免導致火災、觸電或受傷。)

→如需修理，請諮詢Panasonic授權的服務中心。

- 請勿在吸氣口、排氣口或縫隙間插入任何物件。

· 特別是針及其他金屬物件。

(以免導致觸電或異常動作。)

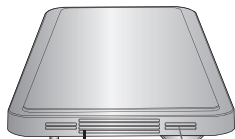

排氣口  
(左側面)



排氣口 吸氣口  
(右側面) (底部)

- 請勿將產品放置於孩童能觸碰到的位置。

(以免導致燙傷、受傷或觸電。)

電源線

電源插頭

電源軟線

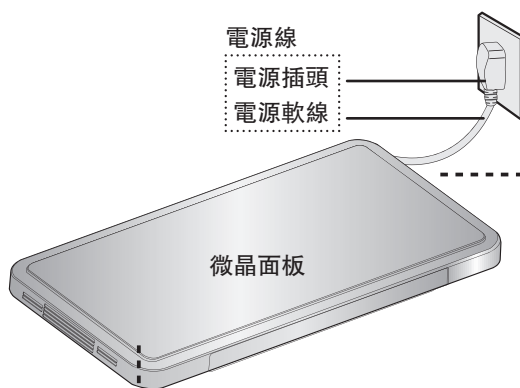

### ■ 微晶面板



- 請勿對微晶面板造成衝擊(重物掉落、放置重物等)。

(以免導致觸電或故障。)

- 請勿將專用烤盤、鍋以外的物品放置在微晶面板上。

→特別是注意以下物品：

· 金屬物件，如刀、叉、勺、專用烤盤的蓋子等。

· 罐頭、暖水壺等密封物品。

· 低耐溫材質的玻璃、陶瓷器具，如：果盤、碗碟等。

(以免因誤加熱而導致起火、爆炸或燙傷。)

- 請勿將紙、布、塑膠等易燃物品墊在微晶面板上加熱。

(以免高溫導致起火。)



- 如果該表面有裂紋，關掉器具以避免可能出現的電擊。

(以免導致觸電。)

■ 希望遵守的內容分類，用如下圖標來區分說明。



此圖標表示不能進行，即“禁止”的內容。



此圖標表示務必執行，即“強制”的內容。



## 警告

### ■ 電源・電源線



- 如電源線已損壞或電源插座與電源插頭的接口鬆脫，請勿使用產品。  
( 以免導致觸電或因短路導致火災。 )  
→如果電源線損壞，為了避免危險，必須由製造商、其維修部或類似部門的專業人士更換。

#### ● 請勿損傷電源線。

- ・絕對禁止進行以下操作：  
損傷、加工、使其接觸或靠近高溫部、強行彎曲、扭轉、拉拔、掛在角上、在其上放置重物、紮成束、夾入、拉動電源線移動。  
( 以免因電源線破損而觸電，或因短路導致火災。 )

#### ● 請勿用濕手插入或拔出電源插頭。

- ・接觸電源插頭或產品前請務必確保手是乾燥的。  
( 以免導致觸電或受傷。 )

#### ● 請勿將水或其它液體濺到電源插頭上。 ( 以免導致觸電或因短路導致火災。 )



- 務必要將電源插頭切實插到底。  
( 以免導致冒煙、火災或觸電。 )

#### ● 務必要單獨使用額定值為AC 220 V/10 A的交流電的電源插座。

- ( 以免因與其他電器並用，因發熱而引起火災。 )  
・務必使用額定值至少為10 A的接線板。

#### ● 本產品應使用單相兩極帶接地的電源插座，並保證其可靠接地。未安裝接地裝置，可能會引起箱體等其他金屬部件帶有感應靜電。 ( 以免發生故障或漏電時有觸電的危險。 )

#### ● 定期清潔電源插頭。

- ( 以免電源插頭因濕氣及外物積聚而導致絕緣不良，從而引起火災。 )

→拔下電源插頭然後使用乾布擦拭。

### ■ 使用



- 烹調油炸、炒菜、燒烤等料理時，請勿中途離開。  
( 以免導致火災。 )

#### ● 請勿在放有鍋具時搬動本體。 ( 以免導致受傷或鍋具損壞。 )



- 本產品不適合供下列人士(包括孩童)使用：身體官能或心智能力退化者，或是經驗與使用知識缺乏者，除非有負責他們安全的人士在旁監督或指導，方可使用。請注意避免讓孩童戲玩本產品。  
( 以免導致燒傷、受傷或觸電。 )

#### ● 加熱液體時，請減小火力並不時地加以攪拌。 ・加熱湯、咖喱等時請特別注意。 ( 以免突然沸騰，液體濺出，導致燙傷。 )

#### ● 發生異常或故障時，請立即停止使用並拔掉電源插頭。 ( 以免導致冒煙、火災或觸電。 )

#### 異常・故障例

- ・電源插頭及電源軟線異常發熱。
- ・電源線已損壞或碰到電源線後發生間歇性斷電。
- ・本體變形或異常發熱。
- ・本體冒煙或發出焦味
- ・本體破裂、鬆動或發出異響。
- ・觸摸本體時有酥麻的電流感覺。

→請立即與Panasonic授權的服務中心聯繫，諮詢檢查及修理事宜。

# 安全注意事項

請務必遵守!

## ! 注意



為避免火災、爆炸、燙傷、受傷、觸電等.....

### ■ 使用

- 使用中或烹調剛結束時，下列部位溫度很高，請勿觸摸。
  - 微晶面板、專用烤盤、烤盤蓋、鍋、排氣口等。
  - ( 以免導致燙傷。 )
- 請勿空燒或過度加熱。
  - ( 以免導致燙傷或烤盤塗層損壞。 )
- 請勿將本產品外接計時器或在獨立的遙控控制系統的方式下運行。
  - ( 以免發生火災。 )
- 請勿在下記地方使用本產品。
  - 靠近熱源或高濕環境中。
  - ( 以免導致觸電、漏電或火災。 )
  - 不平穩的檯面或不耐熱的墊子上。
  - ( 以免導致受傷、燙傷或火災。 )
  - 靠近牆壁或傢俱等處。
  - ( 以免導致傢俱等變色、變形及破損。 )
  - 地面上。
  - ( 以免導致觸電。 )
- 請等到本體充分冷卻後再進行清洗。
  - ( 以免導致燙傷。 )
- 本產品用於家庭和類似用途，例如：
  - 在商店、辦公室及其他工作環境的員工廚房區；
  - 農莊；
  - 酒店，汽車旅館和其他居住環境中由客戶使用；
  - 僅提供床位和早餐的快捷酒店環境。

### ■ 使用專用烤盤時

- 打開烤盤蓋時，請勿接觸蒸氣。
  - ( 以免燙傷。 )
- 蓋把手鬆動時，請重新擰緊後再使用。
  - ( 以免燙傷。 )

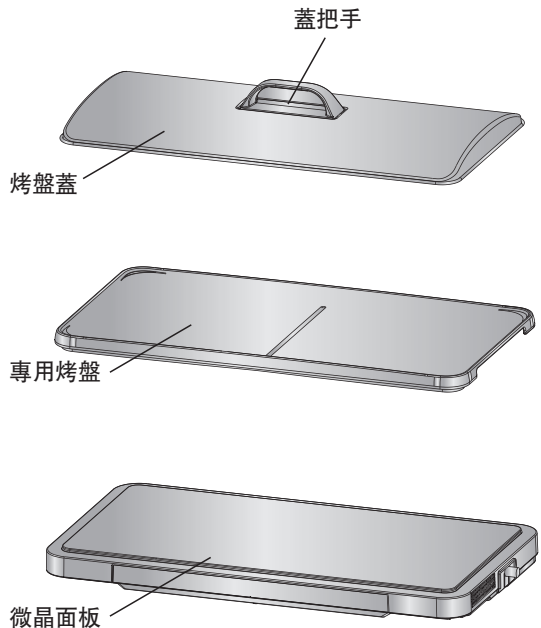

### ■ 烹調油炸料理時

- 請勿使用其他設備加熱過的油。
  - 請務必使用常溫（室溫）油。
  - ( 以免油溫過高，導致火災。 )
- 請勿將臉靠近。
  - ( 以免導致燙傷。 )
- 烹調油炸料理時，油的使用量請勿低於800克（0.9升）。
  - ( 以免油溫過高，導致火災。 )
- 若大量冒煙，請立即拔掉電源插頭。
  - ( 以免導致火災。 )
- 小心油燒熱後飛濺。
  - ( 以免導致燙傷。 )

### ■ 電源 · 電源線

- 拔掉電源插頭時，請確保握住插頭本身。
  - ( 以免導致觸電，或因短路引起火災。 )
- 不使用時，切記關閉電源並拔下電源插頭。
  - ( 以免導致燙傷、受傷或因絕緣老化而引起觸電、漏電、火災。 )

# 使用注意事項

## 關於本體

- 放在滑動式拉桌上時，請務必確認桌子的負荷強度在12 公斤以上。  
( 以免產品掉落。 )
- 定期檢查電熱盤的吸氣口及排氣口，並清除灰塵。  
( 參照第29頁清潔保養。 )
- 使用時，請勿將食材放在排風口附近。  
( 以免熱風使食材風乾，影響口感。 )
- 請勿在戶外使用本產品。  
( 不穩定的電源可能會導致產品發生故障。 )
- 請勿在陽光直射下使用。  
( 以免導致變色。 )
- 請在本體完全冷卻後，再收納起來。  
( 以免燙傷。 )
- 請勿在可能會堵塞產品吸氣口和排氣口的地方使用本產品。  
例如：地毯、塑膠袋、鋁箔及布料等的上面。  
( 以免導致產品內部溫度升高。 )
- 本產品應水平放置，不可緊靠牆面或物品使用，周邊至少確保10 厘米以上的空間，務必保持排風口通暢。  
( 以免導致產品內部溫度升高。 )
- 使用後請及時清潔，防止蟑螂等昆蟲進入機器內部。  
( 以免引起產品故障。 )

## 關於專用烤盤

- 請勿長時間加熱醬汁等的調味料。  
( 以免專用烤盤的烤盤蓋染色髒污。 )
- 請勿將專用烤盤用於本產品以外的地方。  
( 以免專用烤盤變形，無法正確檢知溫度。 )
- 專用烤盤表面的不粘塗層根據使用情況會有所損耗。
  - 可能會形成色斑或剝落，但不會影響產品性能或人身健康。→ 如有需要，請購買新的專用烤盤。
- 請勿長時間蓋烤盤蓋空燒。  
( 以免破壞不粘塗層表面或導致專用烤盤變形。 )
- 請注意以下操作：
  - 請勿使用金屬鏟、叉子、刀等角部尖銳的物品。
  - 使用時請小心輕放，不要掉落或與金屬等硬物碰撞。
  - 烤盤仍處於高溫時，請勿放置於不耐熱的墊子或塑膠製品上，也勿直接用冷水進行急速降溫。
  - 將耐熱容器等放置於烤盤上進行保溫時，表面請鋪上廚房用紙。  
( 以免劃傷不粘塗層表面。 )
- 專用烤盤使用過程中，由於高溫加熱可能會產生輕微變形，這屬於正常現象，請勿擔心。

# 零件名稱

首次使用時，請清洗專用烤盤、烤盤蓋。( 圖 第29頁 )

烤盤蓋

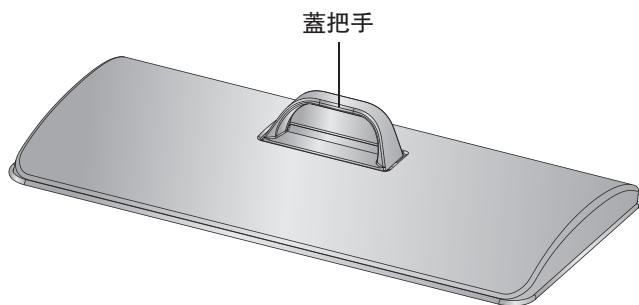

專用烤盤

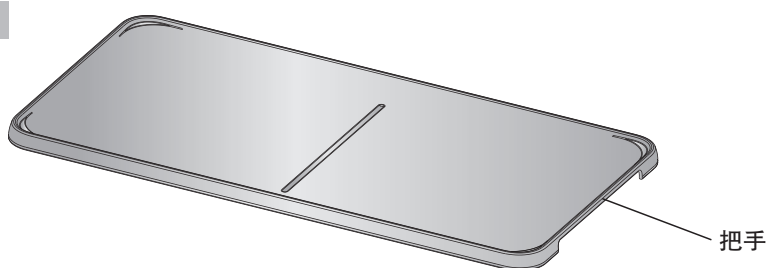

本體

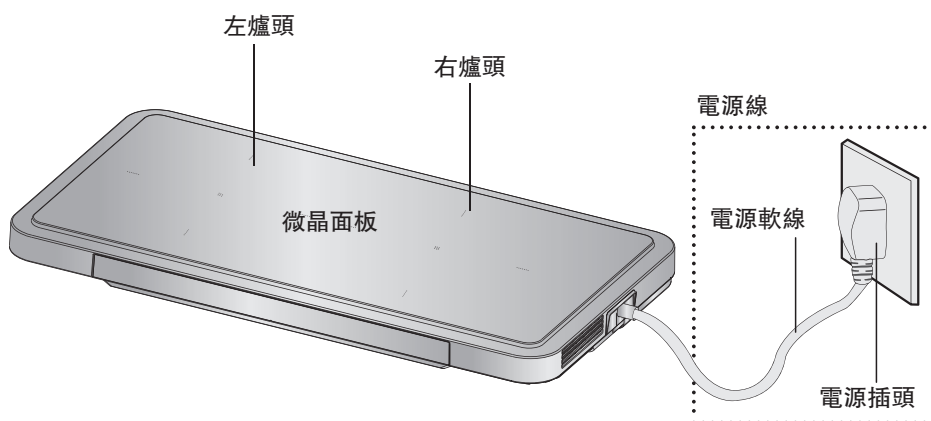

## 操作面板



### + / - 按鍵

- 用於調整加熱溫度或火力。
- 定時功能時，用於調整時間，長按按鍵則可快速前進或後退。

### ◀和▶按鍵

- 要選擇功能時使用。
- 定時功能時，選擇要定時的爐頭時使用。

### [off/on] (關/開) 按鍵

- 開始或結束烹調時按此按鍵。

※ 產品關閉後，若微晶面板表面仍有餘溫，則操作面板上顯示[Hot] ( 高溫 ) 閃爍，此時請勿觸摸，以免燙傷。





烹調效果好



鐵·搪瓷·不銹鋼  
鋁·銅多層鍋

- 搪瓷鍋，要避免空燒、燒焦。  
( 高溫融化後會損傷微晶面板。 )

材質

可能影響加熱效果



耐熱玻璃



砂鍋

使用前

鍋底形狀



平底，  
與微晶面板緊密貼合



圓底



帶支撐腳



底部彎曲

尺寸

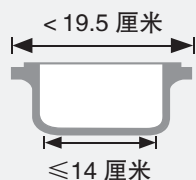

鍋徑： $< 19.5$  厘米  
(左右爐頭同時使用時)  
底徑： $\leq 14$  厘米



$> 19.5$  厘米

※底部過薄的鍋子，在空燒、大火加熱後，可能會產生變形。

同樣火力設定時，由於鍋的材質、形狀、大小等不同，消耗功率會有不同，加熱狀態也會不同。

# 烹調前&開始烹調

## 1 準備

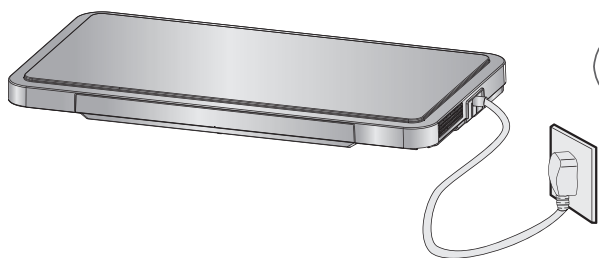
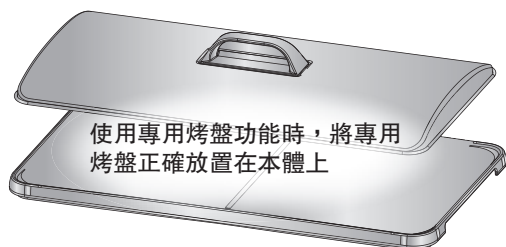

1 請插上電源插頭，確保已插到底。

2 確認電源已接通，進入待機狀態。

### 溫馨提示

30 秒以上未操作時，自動跳轉到待機狀態。

按[<]或[>]後，未操作狀態持續30 秒以上時，自動跳轉到待機狀態，即使不小心按到[off/on]（關/開）鍵，也不會開始加熱。

待機狀態

解除方法：

按除了[off/on]（關/開）鍵以外的任意按鍵，均可解除。

## 2 開始烹調

**專用烤盤** 將專用烤盤正確放置在本體上

1 按[<]或[>]選擇"Special Plate"（專用烤盤）功能。

- 所選功能閃爍。

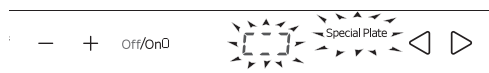

2 選擇想使用的那側爐頭，按[off/on]（關/開）鍵，開始預熱。

- 預熱中"Temp."（溫度）閃爍。
- 預設設定溫度：220℃
- 左右爐頭同時使用時，需要分別設定。

預熱時閃爍

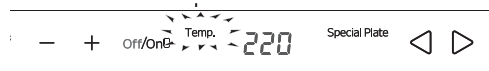

**其他鍋具** 將鍋具正確放置在本體上

1 按[<]或[>]選擇"Others"（其他鍋具）功能。

- 所選功能閃爍。

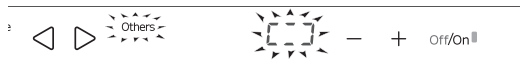

2 選擇想使用的那側爐頭，按[off/on]（關/開）鍵。

- 預設設定火力：4段
- 左右爐頭同時使用時，需要分別設定。

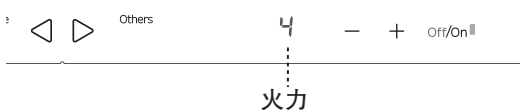

### 3 按[+]或[-]調整設定溫度。

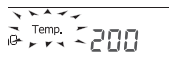

●溫度的範圍：90 °C、140 °C-240 °C

預熱結束，開始烹調。  
(發出“滴滴滴滴”的提示音)



### 4 烹調完成，按[off/on] (關/開) 鍵結束。



- 左右爐頭同時使用時，操作方法一樣，兩側需要分別設定溫度。
- 左右爐頭同時使用時，預熱結束的提示音的提示時間會根據室溫、烤盤的使用情況，有所偏差。
- 本體在未冷卻情況下，再次加熱時不再進行預熱。

#### 溫度調整推薦

溫度約(°C)	90	140	160	180	200	220	240
	保溫	煎蛋		烤薄餅	大阪燒	煎餃	
						牛排	
							炒麵
							烤肉

- 根據食材的份量等，視情況調整溫度。
- 左右爐頭同時使用時所需的加熱時間比單側爐頭使用時要長。

### 3 按[+]或[-]調整火力。

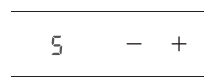

●火力設定範圍：1-10\*段  
※左右爐頭同時使用時，兩爐頭火力相加最大火力為2000 W。

### 4 烹調完成，按[off/on] (關/開) 鍵結束。



- 左右爐頭同時使用時，火力會受到限制，出現火力變弱，小於設定火力的情況。

#### 功率調整推薦

火力表示	1	2	3	4	5	6	7	8	9	10
輸入功率(約)	200 W	400 W	600 W	800 W	900 W	1000 W	1100 W	1200 W	1300 W	1400 W
	微火		弱		中			強		
	慢煮				燉煮			爆炒		
								油炸		

- 根據食材的份量等，視情況調整火力。

# 開始烹調 定時設定



想要在設定時間後自動結束烹調時.....

例：使用專用烤盤（右側）時

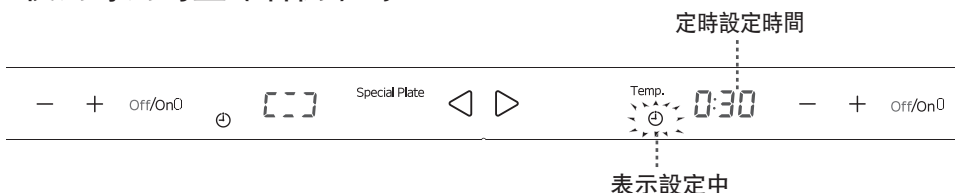

按照第26-27頁的順序設定好溫度或火力後



按[<]或[>]選擇要設定定時的爐頭側。



●所選擇的爐頭側的 ⊕ 閃爍。

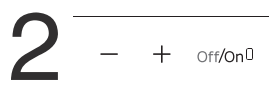

⊕ 閃爍時

按[+]或[-]設定定時時間。

- 長按[+]或[-]按鍵，可快速前進或後退。
- 設定範圍：專用烤盤模式：1分-2小時（90℃時可設定1分-9.5小時）  
其他鍋具模式：1分-3小時
- 時間設定單位如下圖：

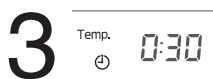
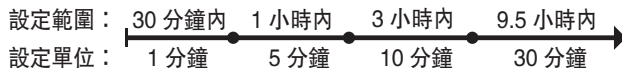

⊕ 3秒鐘後自動轉為長亮

設定結束。

- 顯示定時時間時，溫度或火力不顯示。
- 烹調結束後，自動停止。

左右爐頭可同時使用，操作相同。

- 可設定定時時間的爐頭側，顯示定時設定標識 ⊕。

## ■取消定時設定時

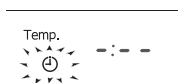

按步驟1·2的操作，將顯示時間調整為"--:--"（如左圖）。

# 清潔保養

## 注意

- 清潔前，務必拔掉電源插頭，等本體冷卻後再進行清洗。
- 清潔時，切勿將本體浸入水中，不要使用天拿水，汽油、酒精，去污粉，硬質刷等擦拭。

### ■ 髒污後請及時清洗。

#### 微晶面板

- 用稀釋後的餐具清洗劑、清潔布及水清洗。

#### ■ 清理油污時

用沾了清洗劑的清潔布擦拭，然後再用洗乾淨的清潔布擦乾淨。

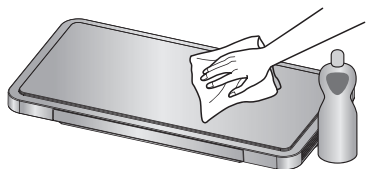

請使用廚房用中性清洗劑



請勿使用以下清洗劑和工具：

- 酸性或鹼性（如漂白劑等）的洗劑，以免變色。
- 硬質刷、去污粉等，以免劃傷。



#### 專用烤盤·烤盤蓋

- 用稀釋後的餐具清洗劑和柔軟的海綿及水清洗。

請立即擦乾烤盤及烤盤蓋上的水。

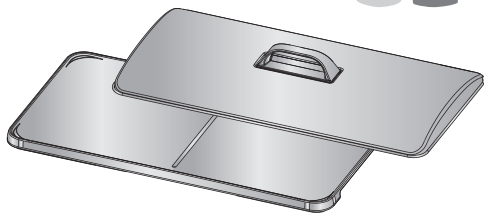
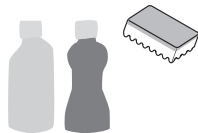

- 請勿使用百潔布的尼龍面，或尼龍製的刷子。
- 請勿使用洗碗機或烘乾機。
- 請不要長時間的把烹調的料理放在烤盤裏，也不要沾有水或清洗劑的狀態下長時間放置。（以免對氟素塗層造成影響。）

#### 本體（吸氣口·排氣口）

- 大約每月檢查一次，如有污垢請及時清洗。

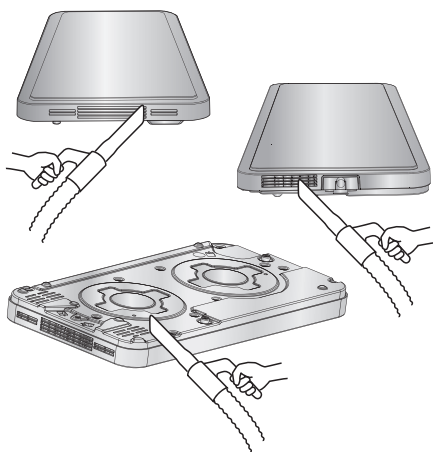

用吸塵器吸除垃圾及異物等。

# 食譜

溫馨提示：食譜中所推薦的溫度、火力、食材量及時間均可根據個人喜好、食材大小及產品使用情況進行調整。

## 煎餃



食材：急凍水餃 15 個

調味料：油 20 毫升  
水 適量

烤盤兩側

- 做法：1) 將油倒入專用烤盤，均勻刷開，然後按[<]或[>]選擇"Special Plate"（專用烤盤）功能，左右爐頭按[off/on]（關/開）按鍵，再按[+]或[-]設定溫度為220℃。
- 2) 預熱結束後，把水餃依次序在專用烤盤上排開，灑上適量清水，然後蓋上外蓋。
- 3) 8-10分鐘後，打開外蓋，水餃若底面焦黃，則逐一翻面再煎5分鐘左右，若還未焦黃則適當增加時間後再翻面。

## 什錦炒麵



食材：麵條 50 克  
雞肉腸 30 克，切粒  
香菇 30 克，切粒  
洋蔥 20 克，切粒

調味料：油 適量  
生抽 20 毫升

烤盤兩側

- 做法：1) 將麵條焯水後撈出瀝乾，倒入10毫升油拌勻備用。
- 2) 將油倒入專用烤盤，均勻刷開，然後按[<]或[>]選擇"Special Plate"（專用烤盤）功能，左右爐頭按[off/on]（關/開）按鍵，再按[+]或[-]設定溫度為240℃。
- 3) 預熱結束後將雞肉腸、香菇、洋蔥放入專用烤盤翻炒約1分鐘，加入麵條和生抽，均勻翻炒約5分鐘即可。

## 香煎巴沙魚



食材：巴沙魚 200 克

調味料：鹽 少許  
黑胡椒粉 少許  
油 適量

烤盤兩側

- 做法：1) 將巴沙魚加鹽和黑胡椒粉，醃制5-10分鐘。
- 2) 專用烤盤中倒入適量的油，均勻刷開，然後按[<]或[>]選擇"Special Plate"（專用烤盤）功能，左右爐頭按[off/on]（關/開）按鍵，再按[+]或[-]設定溫度為220℃。
- 3) 預熱結束後，放入巴沙魚，煎至底面呈金黃色後，翻面同樣煎至底面金黃色即可。

## 休閒燒烤



食材：烤肉用的肉	適量	調味料：油	適量
(牛肉、羊肉、五花肉等，切薄片)		烤肉醬	適量
喜歡的蔬菜、雜菇	適量	鹽	少許
(金針菇、薯仔片等)		胡椒	少許

烤盤兩側

- 做法：1) 將油倒入專用烤盤，均勻抹開，然後按[◀]或[▶]選擇"Special Plate" (專用烤盤) 功能，左右爐頭按[off/on] (關/開) 按鍵，再按[+]或[-]將左右爐頭分別設定溫度為240 °C/180 °C。
- 2) 預熱結束後，把肉類食材放在240 °C盤內，蔬菜、雜菇類食材放在180 °C盤裏，撒上少許鹽和胡椒，一面烤熟後，翻面烤至熟即可。

## 煎牛排



食材：牛排	數片，約100克/片	調味料：油	少許
(約1.0厘米厚，醃制好的)			

烤盤兩側

- 做法：1) 按[◀]或[▶]選擇"Special Plate" (專用烤盤) 功能，左右爐頭按[off/on] (關/開) 按鍵，再按[+]或[-]將左右爐頭分別設定溫度為220 °C/140 °C。
- 2) 預熱結束後，在220 °C的盤面刷上一層油，放入牛排，煎約2分鐘後，翻面再煎約1分30秒鐘。再將煎好的牛排移到140 °C的盤面再煎1分鐘，然後翻面再煎1分鐘 (煎的時間可根據個人喜好調整)。

## 黃金炒飯



食材：冷飯	200克	調味料：油	適量
雞蛋	1個	生抽	15毫升
蝦仁	30克	鹽	少許
洋蔥	20克，切丁		
雞肉腸	30克，切丁		

烤盤兩側

- 做法：1) 將油倒入專用烤盤，均勻抹開，然後按[◀]或[▶]選擇"Special Plate" (專用烤盤) 功能，左右爐頭按[off/on] (關/開) 按鍵，再按[+]或[-]設定溫度為220 °C。
- 2) 將雞蛋打好，待預熱結束後，將雞蛋倒入，炒熟切碎後，將雞肉腸、洋蔥、蝦仁放入專用烤盤翻炒約1分鐘，加入冷飯、鹽和生抽，均勻翻炒約6、7分鐘即可。

# 食譜

## 煙肉金針菇



食材：煙肉 數片 調味料：黑胡椒粉 適量  
金針菇 30 克 油 適量

烤盤兩側

- 做法：1) 金針菇洗淨，切成約5 厘米長的段。取6、7 根左右的量，用煙肉卷起來，用牙籤固定，依次做好全部。
- 2) 專用烤盤中倒入適量的油，均勻抹開，然後按[<]或[>]選擇"Special Plate" (專用烤盤) 功能，左右爐頭按[off/on] (關/開) 按鍵，再按[+]或[-]設定溫度為180 °C。
- 3) 預熱結束後，放入煙肉卷，煎至底面微微焦黃後，翻面同樣煎至底面焦黃，撒上黑胡椒粉即可。

## 港式西多士



食材：吐司 數片 調味料：油 適量  
雞蛋 2 個 花生醬 適量  
煉乳 適量

烤盤兩側

- 做法：1) 將吐司片切掉邊邊，切成四等份。取一塊一塊抹上花生醬，蓋上一層吐司塊，再抹上一層煉乳，再蓋上一塊吐司塊。
- 2) 將雞蛋打好，把疊好的吐司塊裹上雞蛋液。
- 3) 按[<]或[>]選擇"Special Plate" (專用烤盤) 功能，左右爐頭按[off/on] (關/開) 按鍵，再按[+]或[-]設定溫度為160 °C。
- 4) 預熱結束後，盤面刷上一層油，放入吐司塊煎至各面金黃即可。

## 烤薄餅



食材：雞蛋 2 個 調味料：牛油 20 克  
牛奶 100 毫升 白糖 40 克  
蛋糕粉 100 克(非免打發型)  
泡打粉 3 克

烤盤兩側

- 做法：1) 將雞蛋打好，加入白糖和牛奶，攪拌均勻，分次加入蛋糕粉和泡打粉攪拌均勻，再加入牛油，完成餅糊。
- 2) 按[<]或[>]選擇"Special Plate" (專用烤盤) 功能，左右爐頭按[off/on] (關/開) 按鍵，再按[+]或[-]設定溫度為180 °C。
- 3) 預熱結束後，把1)的餅糊攤在專用烤盤上 (每個所用餅糊為一飯勺的容量)。
- 4) 表面出現氣泡且凝固則可以翻面，另一面煎至微微焦黃即可。



## 雞蛋薯仔絲餅



單邊爐頭

食材：薯仔 150 克  
雞蛋 2 個  
蔥花 適量

調味料：鹽 1 克  
粟粉 20 克  
油 15 毫升  
胡椒粉 適量

- 做法：1) 將薯仔切成絲，不用水洗，放入粟粉，雞蛋，攪拌均勻至無乾粟粉即可。  
2) 放入蔥花，攪拌均勻，加入鹽和胡椒粉。  
3) 在平底鍋放入油，倒入剛攪拌好的薯仔絲，鋪平。  
4) 按[<]或[>]選擇"Others"（其他鍋具）功能，按[off/on]（關/開）按鍵，再按[+]或[-]設定火力為"6"段。煎至底面焦黃後，再翻面煎至底面焦黃即可。

## 茶碗蒸



單邊爐頭

食材：雞蛋 1 個  
蝦仁 2 個  
香菇 2 片  
水 適量

調味料：鹽 少許  
料酒 10 毫升

- 做法：1) 雞蛋打散，按雞蛋：水=1：3的比例加入清水，並放入少量鹽和料酒均勻混合後撇去浮沫，蝦仁加入鹽和料酒醃制5分鐘，香菇泡發後洗淨切片。  
2) 在茶碗底放1個蝦仁，倒入蛋液不超過8分滿，蓋上杯蓋（無杯蓋的可用保鮮膜），放入裝了水的鍋中。  
3) 按[<]或[>]選擇"Others"（其他鍋具）功能，按[off/on]（關/開）按鍵，再按[+]或[-]設定火力為"8"段。水沸騰後，蒸8分鐘左右，打開杯蓋，鋪入1個蝦仁，2片香菇，蓋上杯蓋繼續蒸8-10分鐘即可。

## 關東煮



單邊爐頭

食材：白蘿蔔 100 克  
海帶結 適量  
喜歡各種食材  
（丸子、薯仔等） 適量  
水 1000 毫升

調味料：關東煮湯料 1 包

- 做法：1) 將關東煮湯料用水調配好倒入鍋裏，將白蘿蔔去皮，切2厘米左右厚，與海帶結一起放入鍋裏。  
2) 按[<]或[>]選擇"Others"（其他鍋具）功能，按[off/on]（關/開）按鍵，再按[+]或[-]設定火力為"8"段。  
3) 燉10分鐘後，加入自己喜歡的食材，按[+]或[-]將火力調整到"4"段，繼續燉約45分鐘，入味即可。

# 疑難排解

並非故障，在委託維修之前請先進行檢查。



現象	原因
按各按鍵後無反應	<ul style="list-style-type: none"><li>● 是否插好電源插頭？</li></ul>
使用中返回待機	<ul style="list-style-type: none"><li>● 一定時間（約兩小時）不進行任何按鍵操作，會自動停止加熱（保護功能啟動），返回待機狀態。</li><li>● 是否設定了定時功能。</li></ul>
使用中火力變弱	<ul style="list-style-type: none"><li>● “溫度過升防止”功能啟動。<ul style="list-style-type: none"><li>· 加熱時間過長等導致鍋底溫度過度上升時，會自動控制通電。（溫度下降後火力會自動變強。）</li><li>· 空燒時。（請確認鍋內情況。）</li></ul></li></ul>
左右爐頭同時使用時 <ul style="list-style-type: none"><li>● 火力變弱</li><li>● 火力顯示自動變小</li><li>● 火力無法上升</li></ul>	<ul style="list-style-type: none"><li>● 為了不超過總輸入功率，自動調整，限制火力。</li></ul>
油炸料理時，預熱時間過長或油溫過低	<ul style="list-style-type: none"><li>● 是否用熱油進行預熱？</li><li>● 是否在微晶面板未冷卻時烹調？</li><li>● 鍋底·微晶面板是否有髒污？</li><li>● 是否使用熱油·茶褐色的油·渾濁的油？</li><li>● 是否有油炸的殘渣？</li></ul>
左右同時使用"Special Plate"（專用烤盤）功能時，預熱完成蜂鳴音的時間不一致	<ul style="list-style-type: none"><li>● 即使設定的時間一樣，由於室溫、專用烤盤使用狀態、溫度等影響，左右爐頭的報知蜂鳴音的時間會有所偏差。</li></ul>
沒有使用時風扇發出聲音	<ul style="list-style-type: none"><li>● 本體內部的溫度過高時，冷卻風扇會啟動。（溫度下降後，會自動停止。）</li></ul>

## 注意

使用時，未加熱或火力持續減弱，請嘗試拔下電源插頭，重新插入，選擇功能，再按 [off/on]（關/開）按鍵。

# 當出現這樣的顯示時

在委託維修之前請先進行檢查。

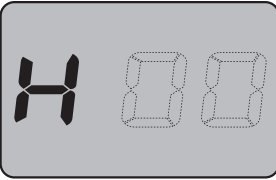
錯誤顯示	請檢查	頁碼
	<ul style="list-style-type: none"><li>● 產品吸氣口及排氣口是否有灰塵等異物阻塞？ →請按下記步驟清除灰塵。 ①按[off/on]（關/開）按鍵，然後拔掉電源插頭。 ②待產品冷卻後，清除產品的吸氣口/排氣口中的灰塵。 （ 第29頁）</li><li>● 產品是否有在地毯等物品上使用？ →請勿在可能會堵塞產品左右側的地方使用本產品。</li></ul>	—  23
	<ul style="list-style-type: none"><li>● 嘗試拔下電源插頭，再重新插入，選擇功能，再按[off/on]（關/開）按鍵。 如仍出現"H※※"，則表示存在故障。 →請諮詢Panasonic授權的服務中心，並告知錯誤代碼（"H"後的兩位數字）。</li></ul>	—

當進行了上述處理後仍不能恢復正常時，請委託Panasonic授權的服務中心修理。

# 規格

型號		NF-X1-N
額定電壓		220 V~
額定頻率		50 Hz
額定輸入功率		雙爐頭2000 W，單爐頭1400 W
溫度調節	保溫	90 °C
	加熱	140 °C-240 °C
火力調節	其他功能	1-10段
電源線長度（約）		1.8 m
本體	尺寸（約）（寬×深×高）	472 mm×260 mm×48 mm
	重量（約）	3.4 kg
專用烤盤	尺寸（約）（寬×深×高）	459 mm×249 mm×86.6 mm（含烤盤蓋）
	重量（約）	2.0 kg（含烤盤蓋）